

CABINET FAN TO TURN ON AT 96, OFF AT 79 DEGREES C EXHAUST PIPE TEMPERATURE

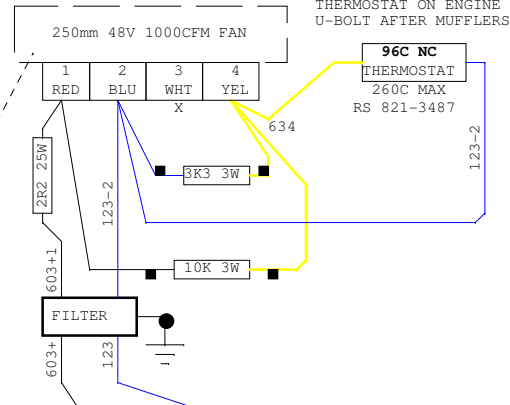

MODULAR GENSETS HAVE EXTENSION HARNESSSES TO FIT WIRING TO LARGER CHASSIS

COMBINED BLOWER / FILTER / BRAKE UNIT

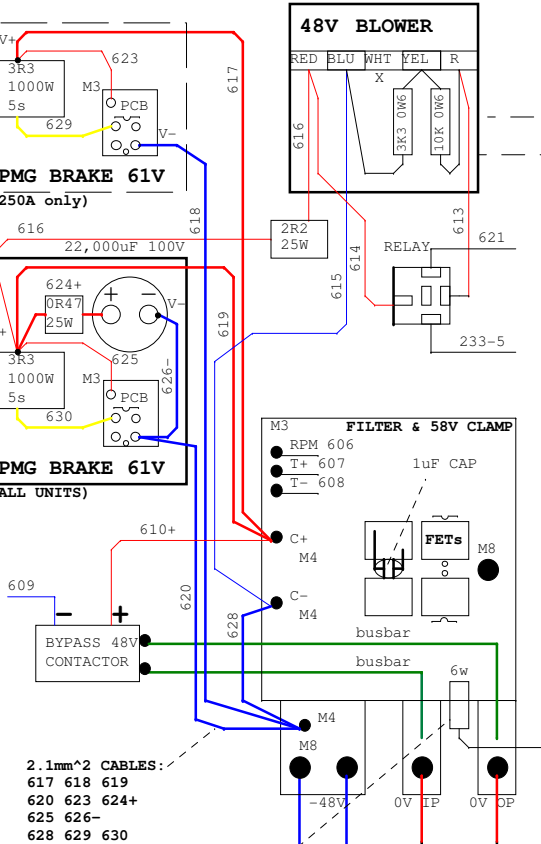

- 2.1mm² CABLES:**
 617 618 619
 620 623 624+
 625 626-
 628 629 630

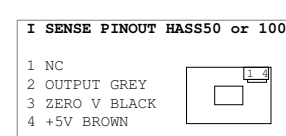

ALL CABLES AUTOMOTIVE RATED 105 DEGREES C AND OIL RESISTANT. **CABLE TIES MUST NOT CRUSH CABLES.** SECURE CABLES TO ENGINE WITH INSULATING FIXINGS. DOUBLE INSULATE PARTS / CABLES WHERE TOUCHING METAL. SECURE ALL CABLES AND HOSES AGAINST VIBRATION. STRAIN RELIEVE ALL CABLES. PROTECT CABLES FROM METALWORK VIBRATION AND EDGES. STANDARD WIRES 22AWG 0.7MM². SOME STD WIRES ARE MULTICORE. ALL THERMOCOUPLES ARE 24AWG, TIP ELECTRICALLY INSULATED. CONTROL PANEL MUST BE GROUNDED TO CHASSIS. SITE TO BE CORRECTLY GROUNDED TO MINIMISE LIGHTNING RISK.

PERKINS 1.1/1.5 DIESEL ENGINE

